

## MODENA CHROME FINISH ELECTRONIC SOAP DISPENSER SPECS

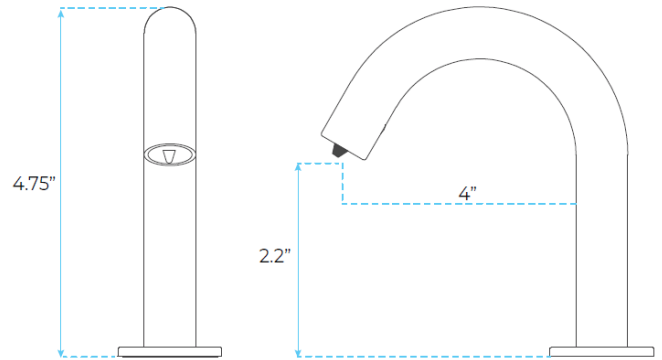

### SPECS:

Product Type: Commercial

Main Construction Material: Brass

Mount Type: Deck

Handle Type: Infra-Red

Power Rating: 3 Amp Fuse, AC: 230V DC:  
1.5V

Batteries Required: 4 AA Batteries (not  
supplied)

Number of Tap Holes: 1

Valve/Cartridge Type: Solenoid Valve

Plumbing System Requirements: Suitable  
for all plumbing systems

Sensing Range: 2.4-3.9 in (6-10 cm)

Activation Time: 0.5 - 1 secs

Counter Top Specs: Hole size: MIN 1"..  
Thickness: MAX 2"

Soap Bottle Capacity: ~1600 (Just Under  
Half Gallon) optional 1 gallon

